

# Integraged Sensor Faucet KEGE-8904L

- **Product Details: Integraged Sensor Faucet (for above basin) KEGE-8904L**

Intergrated faucet for above basin

## Integraged Sensor Faucet Features:

- 1.Control:Designed with SCM. Stop water automatically when water flowing exceed 1 minute.
- 2.Adjustable distance: Induce distance can be adjusted free of touching.
- 3.Strainer device: Strainer can be removed and clean to prevent blocking.
- 4.Check valve :Check valve inside the faucet body.
- 5.Structure: All parts are included inside the faucet. With warm & cold adjusted handle.
- 6.The length of faucet can be customized

## Technical Data:

Model	DC	AC	AD
Power Supply	DC:6V	AC:110V.220V-240V 50Hz-60Hz	AC:220V-240V.50Hz-60Hz DC:6V(Auto Swith)
Faucet Body Material	Brass		
Applicable Water Pressure	0.05-0.7MPa		
Water Temperature	0.1-60°C		
Environment Temperature	0.1-45°C		
Water Supplying Caliber	G1/2.G3/8		

## Overall dimensiions:

## Installation diagram:

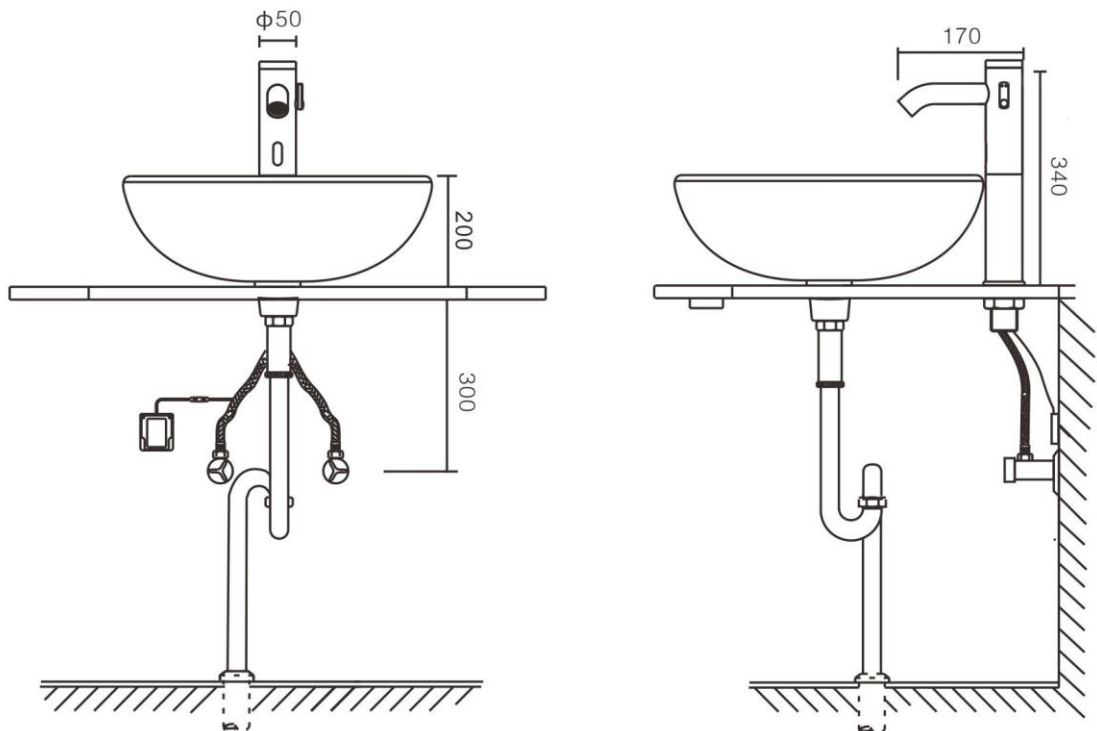
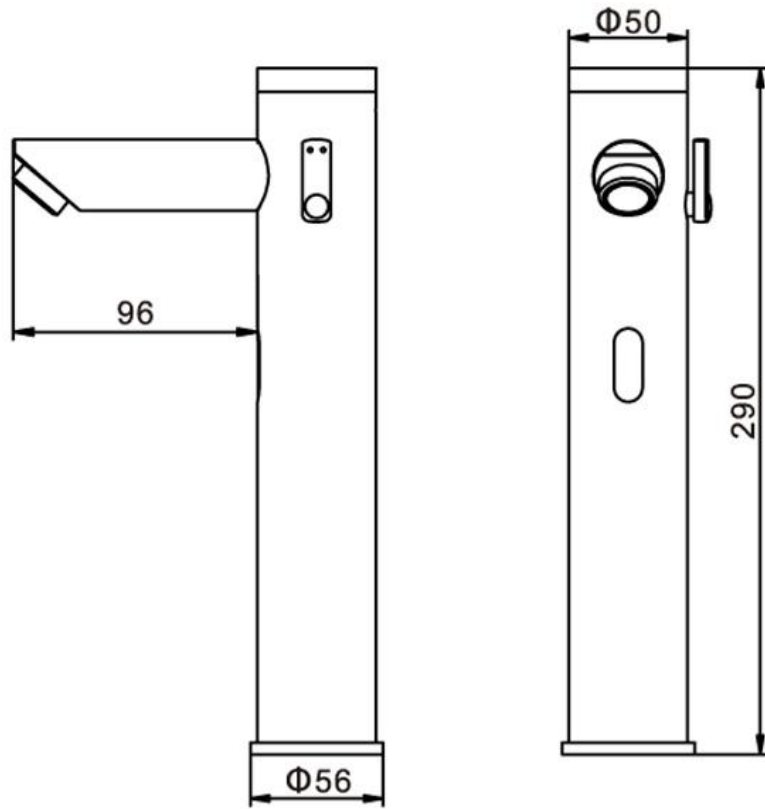

Instructions for use:

1. Sensor/flow test.

When the unit is powered on, water should flow immediately when you put your hands within range of the sensor. When you remove your hands out range the water should stop immediately.

The maximum duration of continuous flow is 1 minute.

2. Sensor range

The default factory set distance is 12~15 cm. When powered on for the first time, place your hands at the desired distance within 5 seconds after the power has been switched on and remove your hands after approx 2 seconds in order to change the factory setting.

To reset the setting, interrupt power for at least 30 seconds and follow the procedure as described to set the sensor range correctly.

3. Strainer

To prevent blockage please clean the strainer regularly, make sure you shut of the water mains, unscrew the water inlet hose, remove the strainer, clean with water and a soft brush. Then install the items in reverse order, turn on water mains and check for leakage.

**Battery Change:**

The indicator light in the sensor will flicker 3 times per second to indicate the batteries are at the end of their useful life. At this stage the unit will not operate in battery more anymore

In case you have plugged in the mains, disconnect power and open the cover of the control box, open the battery holder, remove the batteries and replace all batteries with new ones.

Please make sure you install the batteries in the right direction, the + and – side are indicated in the battery holder.

Close the battery holder, place the cover back in place and tighten the screws.

Follow the instructions for setting the sensor range if required.

**Problem:**

The unit does not work. Please check for power connection or replace the batteries, check connection of the sensor cable.

There is power however no water flow,

Please check the water supply, open any closed valves if necessary

Check water connections for blockage, clean if necessary

Check Strainer for Blockage, clean if necessary

Disconnect power for 30 seconds and re install

Check water connections for twists

Check sensor cable connection

Clean the sensor with a soft cloth

**Caution:**

Please handle the product with care whilst installing

Only clean with soft cloth, no abrasive cleaning agent, acidulous cleaning agents.

Do not spray the control with water.

Only clean the sensor with a soft cloth, scratching will reduce the range and sensitivity of the unit itself

